

PRODUCT SPECIFICATION

Single-dual Color LED Control Card
HD-E62

1. Overview

HD-E62 (referred to as E62) is a single/dual-color series LED display control card that supports LAN and USB communication. It can display various content including text, animated text, GIF animations, Excel, timing, temperature (humidity), countdown, count-up, lunar calendar, etc. The supporting software features a simple interface, easy operation, and high cost-effectiveness.

Application Software:

PC: HDSign (HD2020);

Mobile: "LedArt APP" and "LedArt lite APP" (can be used with Wi-Fi connection);

Cloud: XiaoHui Cloud Software.

2. Connection Diagram

1. Setting parameters and updating programs through direct connection via Ethernet cable to a computer or U-Disk.

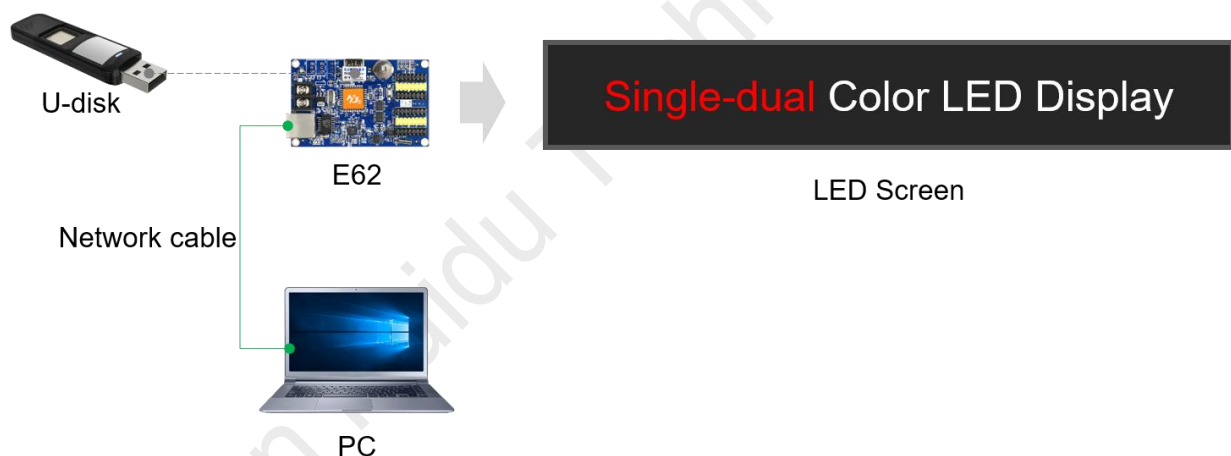

2. Supports LAN control, and can be wirelessly controlled via the "LedArt APP" through LAN connection.

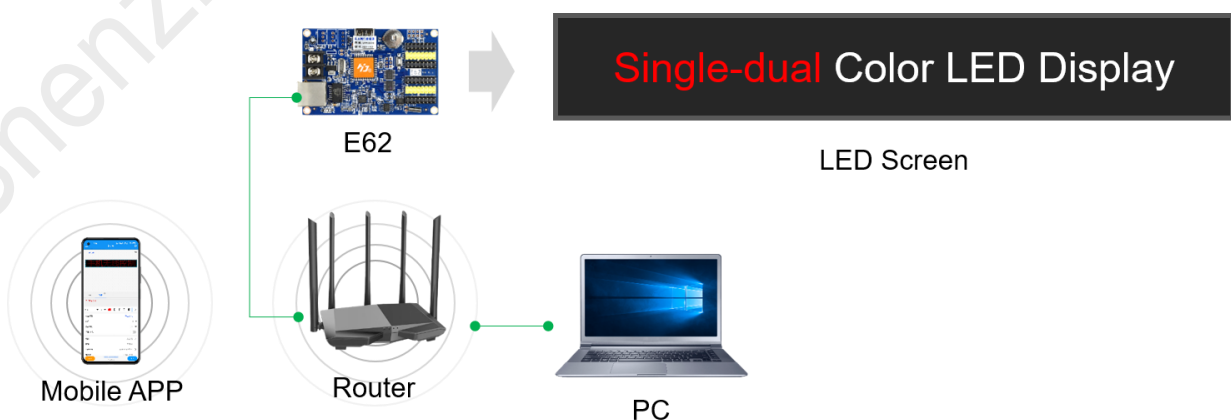

3. Function List

Content	Function description
Control range	Single color: 1024* 64, Max Width: 2048 Max Height: 64; Dual color 512*64
FLASH Capacity	4M Byte (Practical usage 3.5MB)
Communication	U-Disk、 LAN
Program Quantity	Max 1000pcs Programs. Support play by time section or control by buttons.
Area Quantity	20 areas with separate zone, and separated special effects and border
Display Showing	Text、 Picture、 3DText、 Animation (SWF)、 Excel、 Timing、 Temperatures (humidity)、 Count、 Lunar calendar
Display	Sequence display, button switch, remote control
Clock function	1、 Support Digital Clock/ Dial Clock / Lunar Time 2、 Countdown /Count up, Button Countdown / Count up 3、 The font、 size、 color and position can be set freely 4、 Support multiple time zones
Extended Equipment	Temperatures、 Humidity、 IR Remoter、 Photosensitive sensors、 etc.
Automatic switch screen	Support timer switch machine
Dimming	Support three brightness adjustment mode

4. Port Definition

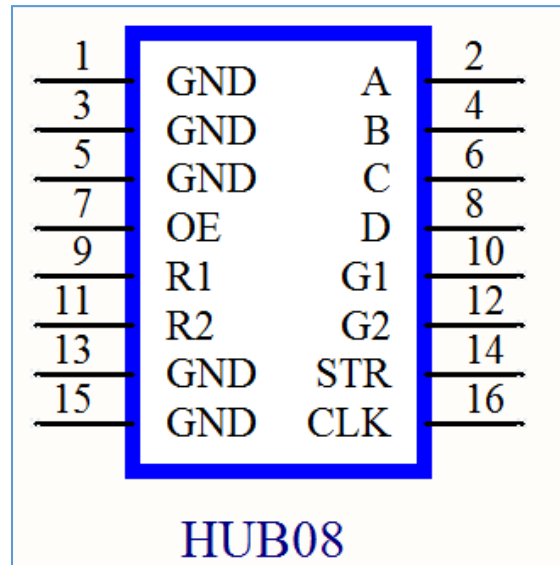
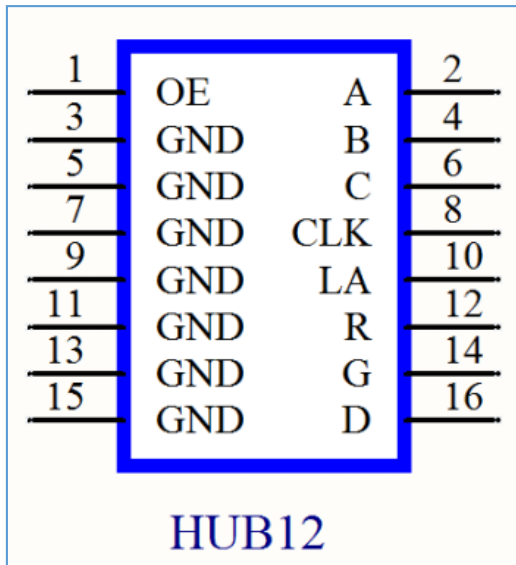

5. Size Diagram

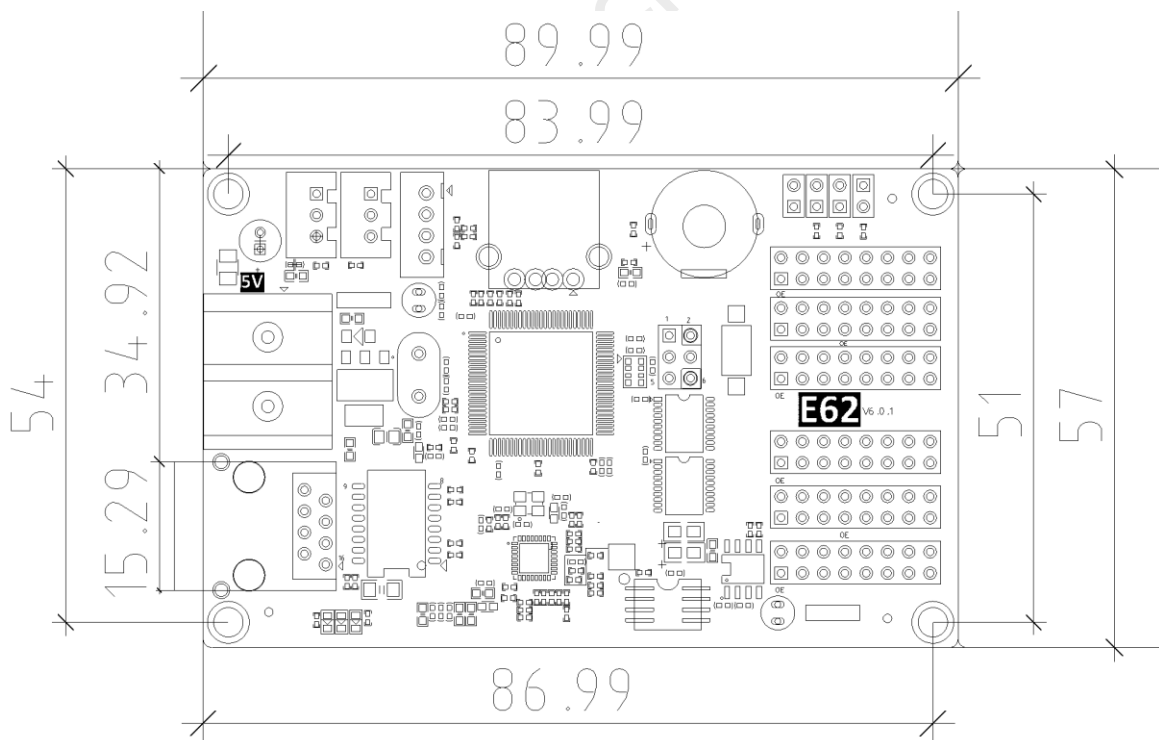

6. Interface Description

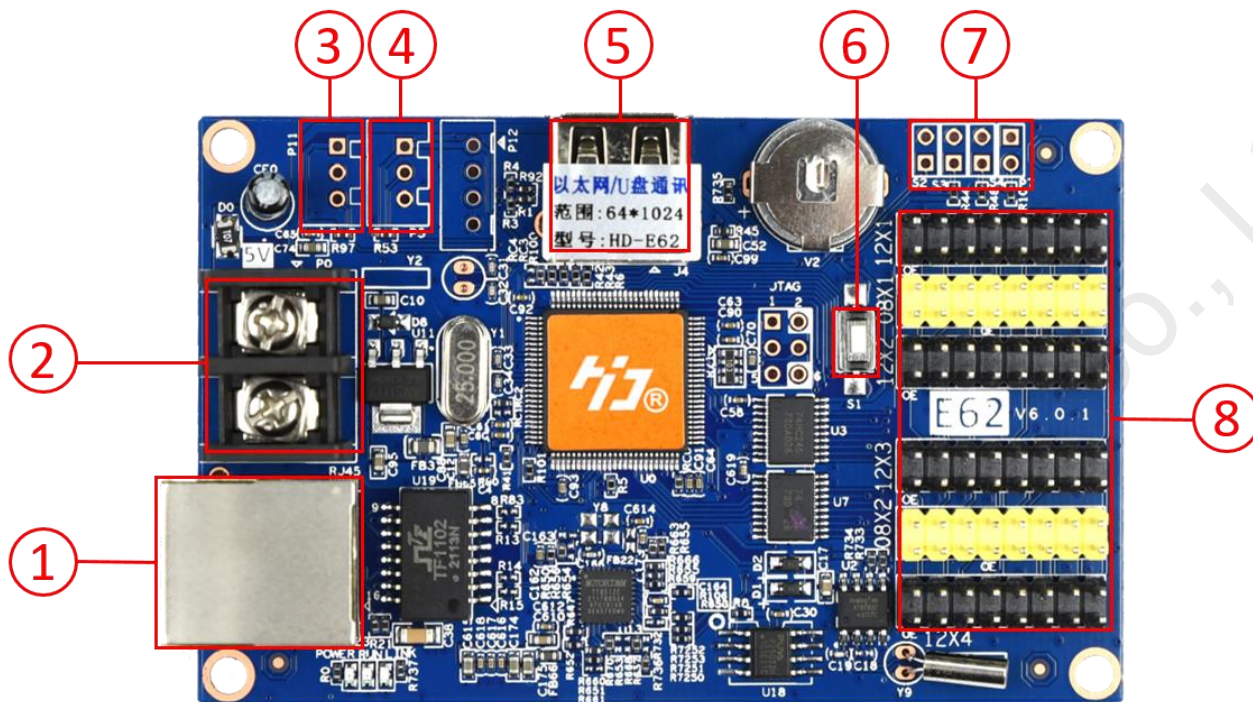

Serial number	Name	Description
1	Ethernet port	Connect the computer through Ethernet to send parameters and programs ;
2	Power inport	Connect to a 5V DC power supply
3	P11	Connect the IR, by remote control.
4	P5	Connect the temperature/humidity sensor
5	USB ports	Updated program by U-disk
6	S1	click to switch screen test status
7	Keypad ports	S2: Connect the point switch, switch to the next program, the timer starts, count plus S3: Connect the point switch, switch the previous program, timer reset, count down S4: Connect the point switch, program control, timing pause, count reset
8	HUB ports	4 HUB12, 2 HUB08, For connecting to the display

7. Basic Parameters

Parameter Term	Parameter Value
Work voltage (V)	DC 4.2V-5.5V
Work temperature (°C)	-40°C~80°C
Work humidity (RH)	0~95%RH
Storage temperature(°C)	-40°C~105°C

Precautions:

- 1) To ensure that the control card is stored during normal operation, make sure the battery on the control card is not loose;
- 2) In order to ensure the long-term stable operation of the system; please try to use the standard 5V power supply voltage.